

# *Proportional Pinch Valves*

## **HPPV SERIES MANUAL**



# CONTENTS

Introduction .....	3
Valve Description.....	4
Electrical Specifications.....	7
Valve Options.....	8
Control Requirements .....	9
Advantages of Microstepping .....	10
Thrust vs Speed Performance Curve .....	11
CE Certification & RoHS Certification .....	12
Recommended Tube Type .....	13
Wiring Diagram with Steppping Squence .....	14
Valve Operation .....	15

# INTRODUCTION

---

## A Simple New Approach that is Sanitary, Efficient, and Cost Effective

Achieving both sanitary fluid separation and flow control is easier than ever with a new, patented technology that offers a variety of design advantages to developers of OEM products for industries including:

- *Biotechnology*
- *Chemical Processing*
- *Dispensing, Filling, & Mixing*
- *Process Equipment*
- *Bioreactors*
- *Medical Devices*
- *Pharmaceuticals*
- *Life Sciences*

## Patented Technology - Accuracy, Flow, and Separation

Preserving the integrity of a fluid passing through a non-contact system is essential in a variety of sanitary applications. Ever-increasing levels of sophistication in new technologies have led to more stringent performance demands, and processes need to be regulated with greater speed and accuracy. Needle valves have excellent fluid metering characteristics but poor fluid separation characteristics. Conversely, pinch valves have superior fluid separation characteristics but inadequate fluid metering ability. In order to meet application requirements, these two types of valves would typically be used in tandem.

Recognizing the need for a better approach, Resolution Air, Ltd. Founder and Senior Design Engineer, Brad Thompson set about developing a hybrid valve combining the fluid metering characteristics of the needle valve with the fluid separation of the pinch valve. The Hybrid Proportional Pinch Valve (HPPV), was developed to deliver tight specifications for high-resolution flow control. The HPPV series can be integrated into portable and handheld equipment in a variety of key industries, including life sciences and medical devices, food and beverage, and healthcare.



*On 10-31-2017, Resolution Air, Ltd. was issued U.S. Patent No. 9,803,754 by the U.S. Patent and Trademark Office.*

# VALVE DESCRIPTION

---

Resolution Air, Ltd.'s Proportional Pinch Valves allow the benefits of pinch valve fluid separation to be combined with proportional valve control for sanitary processes requiring highly accurate, fluid metering where cleanliness and sterility is required. Furthermore, the HPPV- series generates significant more pinch force (50 lbs.) than a traditional solenoid valve and does it without the expense of compressed air. Valves come standard with a hall-effect home sensor. An optional encoder is available.



Each valve consists of a Hybrid bi-polar stepper motor. The motor receives square wave pulses (PWM) from either a driver or driver/controller. For these motors, each square pulse translates into a single step or rather a 1.8 degree rotation of the motor. Attached to the motor is an integral leadscrew which converts 1 step of rotation into .00048" linear movement. A custom piston with an elastomeric seal is attached to the end of the lead screw which then accurately positions the piston. This allows tubes to be pinched with fine control for the metering of liquids and gases. Sizes from range from ¼" - 1.00" O.D. tube.

Hybrid Proportional Pinch Valves (HPPV) combine the precise fluid metering abilities of a proportional valve with the sanitary fluid separation characteristics of a pinch valve. This larger valve series utilizes a robust and powerful linear actuator capable of generating 50 lbs. of pinch force ideal for higher pressure systems and tube sizes up to 1.00" O.D.

A primary benefit of proportional pinch valves is automating the metering process of liquids and gases in open and closed loop control systems. In addition, Resolution Air, Ltd valves are also being utilized in applications requiring simple ON/OFF control because they generate significantly higher pinch forces (12x) compared to a traditional solenoid pinch valve. As a result, our valves are quickly replacing traditional low force solenoid pinch valves in many markets including medical device and life sciences, where precise sanitary fluid metering is critical to the application.

**Valve Advantages**

- ✓ Automated control
- ✓ No physical contact with process fluid
- ✓ High resolution flow control
- ✓ Home switch provides digital output for full open position
- ✓ Durable construction
- ✓ Tested performance
- ✓ High repeatability
- ✓ Low power consumption
- ✓ No leakage
- ✓ Long performance life
- ✓ Light weight, low profile design
- ✓ Superior corrosion resistance
- ✓ Valve body material option: Stainless Steel

**Performance Characteristics**

Standard Tube Sizes (O.D.)	1/4", 3/8", 1/2", 3/4", 1.00"
Recommended Tubing Durometer	50-80 Shore A
Maximum Temperature	180° F
Motor Type	Bi-Polar Stepper Motor
Position Resolution	.00048" / step
Power Consumption	5.7 Watts
Motor Supply Voltage	24-40 VDC Unregulated Power Supply
Maximum Current / Phase	0.57 A rms
Electrical Connection	12" Wiring Harness (included)
Driver Requirements	Bi-Polar Chopper Drive
Home Switch	Hall Effect - Full Open Position
Home Switch Supply Voltage	3.8 - 24 VDC
Maximum Pinch Force	50 lbs @ 100 steps / second

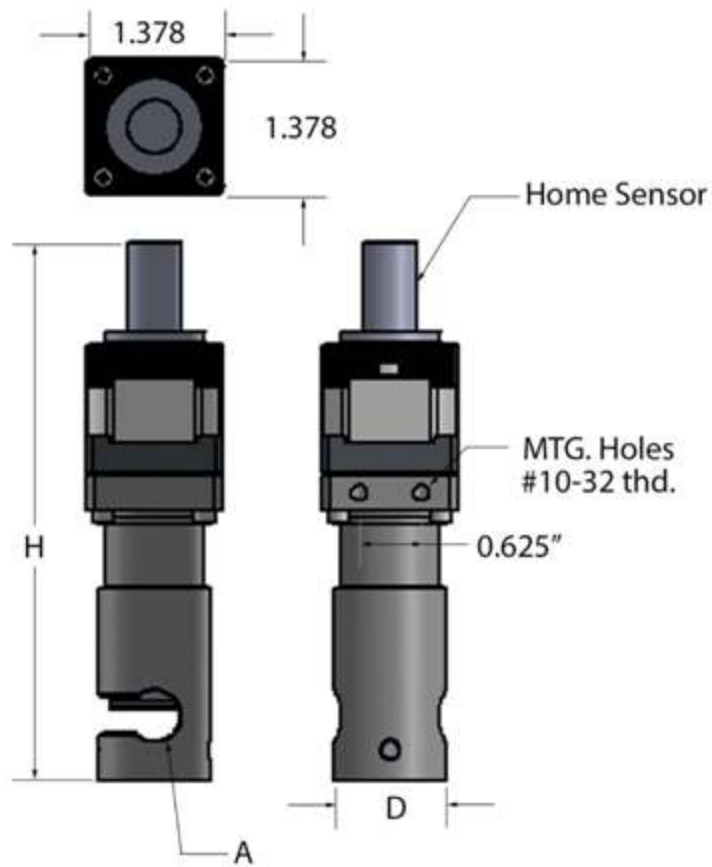

Valve Model	A Tube Size (O.D.)	H Overall Height	D Overall Diameter	Travel Rate*
HPPV-4	.250"	4.915	0.938	.52 sec.
HPPV-6	.375"	5.062	0.938	.78 sec.
HPPV-8	.500"	5.418	1.125	1.04 sec.
HPPV-12	.750"	6.027	1.498	1.56 sec.
HPPV-16	1.00"	6.562	1.875	2.08 sec.

\*Full open to full close @ 1000 steps / second

### Valve Applications

- ✓ Chemical Mixing / Dispensing
- ✓ Dosage Systems
- ✓ Clinical or Chemical Analysis
- ✓ Vending Machines
- ✓ Blood Handling / Analysis
- ✓ Lab Analysis

# ELECTRICAL SPECIFICATIONS

## Recommended Power Supply

In general, unregulated DC (or linear regulated) power supplies are best suited for stepper motor applications. Switching power supplies tend to be very cost efficient and are also suited for many stepper motor applications. Bear in mind their ability to provide surge currents is limited and may require additional capacitors, depending on the application. The stepper linear actuators used in HPPV valves are rated at 5 VDC. Please note that the motors need to be powered from 5 to 8 x the rated voltage (24 to 40 VDC).

## Home Sensor

Resolution Air, Ltd's HPPV-Series of Proportional Pinch Valves are equipped with a hall-effect sensor used to indicate when the valve is full open. The sensor incorporates a hall-effect device, which is activated by a rare earth magnet embedded in the end of the internal screw. The compact profile of the sensor allows for the installation in limited space applications. The sensor has virtually unlimited cycle life. Special cabling and connectors can be provided. See Below for the sensor technical data.

Supply Voltage (VDC):	3.8 min to 24 max.
Current consumption:	10 mA max.
Output voltage (operated):	0.15 typ., 0.40 max.; Sinking 20 mA max.
Output current:	20mA max.
Output leakage current (released):	10µA max. @ Vout = 24VDC; Vcc = 24VDC
Output switching time	
Rise, 10 to 90%; .05µ typ., 1.5µ max. @ Vcc = 12 V, RL = 1.6 KOhm	Fall, 90 to 10%; .15µ typ., 1.5 µs max. @ CL = 20 pF

## Typical Home Sensor wiring

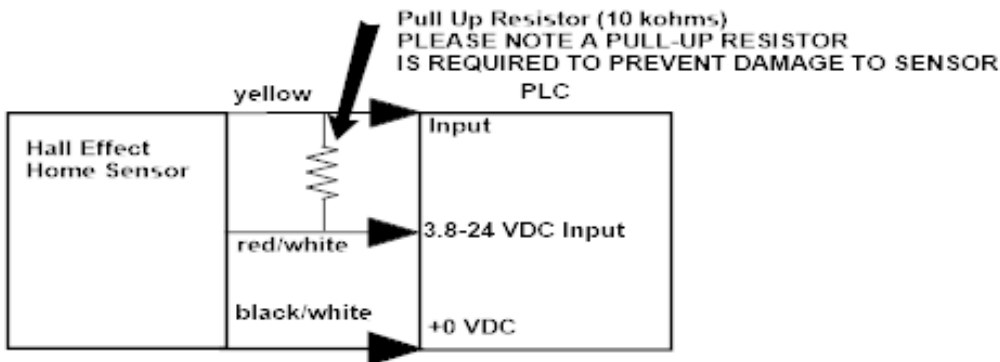

## Additional Home Sensor wiring examples

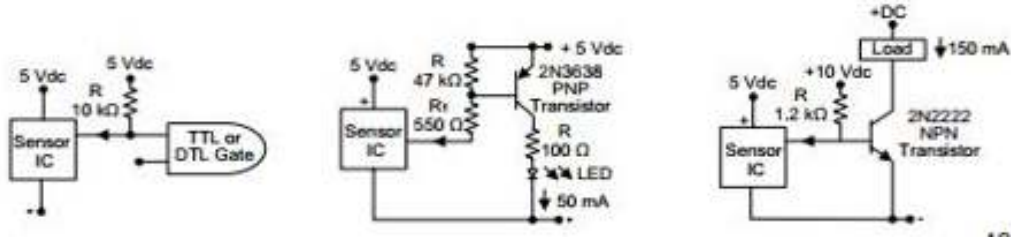

# VALVE OPTIONS

### Optional Encoder

Encoder Type	2 Channel Quadrature TTL Squarewave Outputs
Counts/Rev.	400
Index Type	Non-Index
Output	Single Ended
Supply Voltage	VDC (24 VDC Optional)
Supply Current (TYP.)	29 Ma.

### Encoder Cable

5 VDC	ES
24 VDC	E24
Cable Length	2 FT.



# CONTROL REQUIREMENTS

The bi-polar stepper motors used in the Miniature Proportional Pinch Valve require two input control signals, a step signal and a directional signal.

**Step Signal** - A Pulse Width Modulated (PWM) signal, Each pulse generates a single step. For the HPPV-series, a single step equates to 1.8 degrees of motor rotation. Since the motor shaft is coupled to an integral leadscrew, this rotation translates into  $.00048''/\text{step}$  of linear motion.

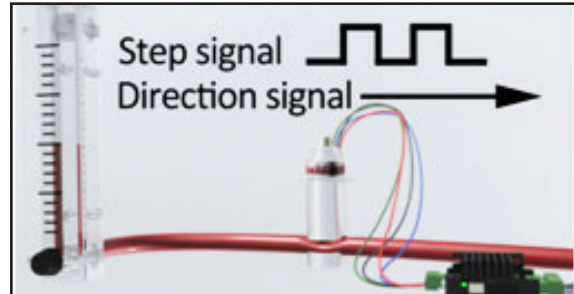

**Direction Signal** - A digital binary signal which determines the clockwise /anti clockwise motor rotation.

There are two primary methods for generating and amplifying step and directional control signals.

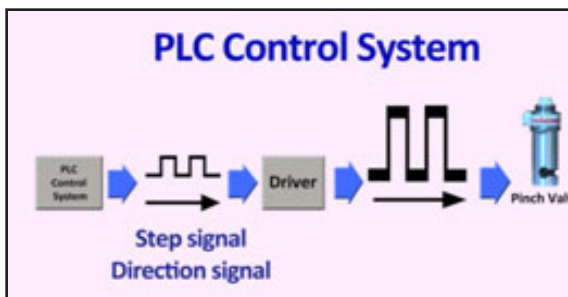

## PLC Based Control System

Signals generated by a Programmable Logic Controller (PLC) are amplified by a Bi-Polar Chopper Driver (DRV-1) to the level required to drive the motor.

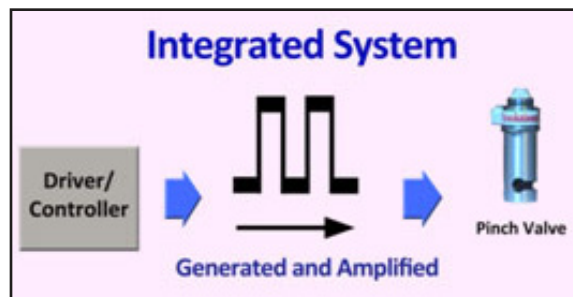

## Bi-Polar Driver/Controller System

The step and direction signals are generated and amplified by a single control device known as a Bi-Polar Driver/Controller.

# ADVANTAGES OF MICROSTEPPING

Microstepping is a method of controlling stepper motors. It is an integral part of our Bi-polar chopper drive , DRV-1. where it is dip switch selectable. Its function is to achieve higher flow resolution. The graph below reveals how microstepping improves the flow resolution of our proportional pinch valves.

Resolution Air, Ltd.: DRV-1 Drive  
MICRO-STEPPING AND FLOW RESOLUTION

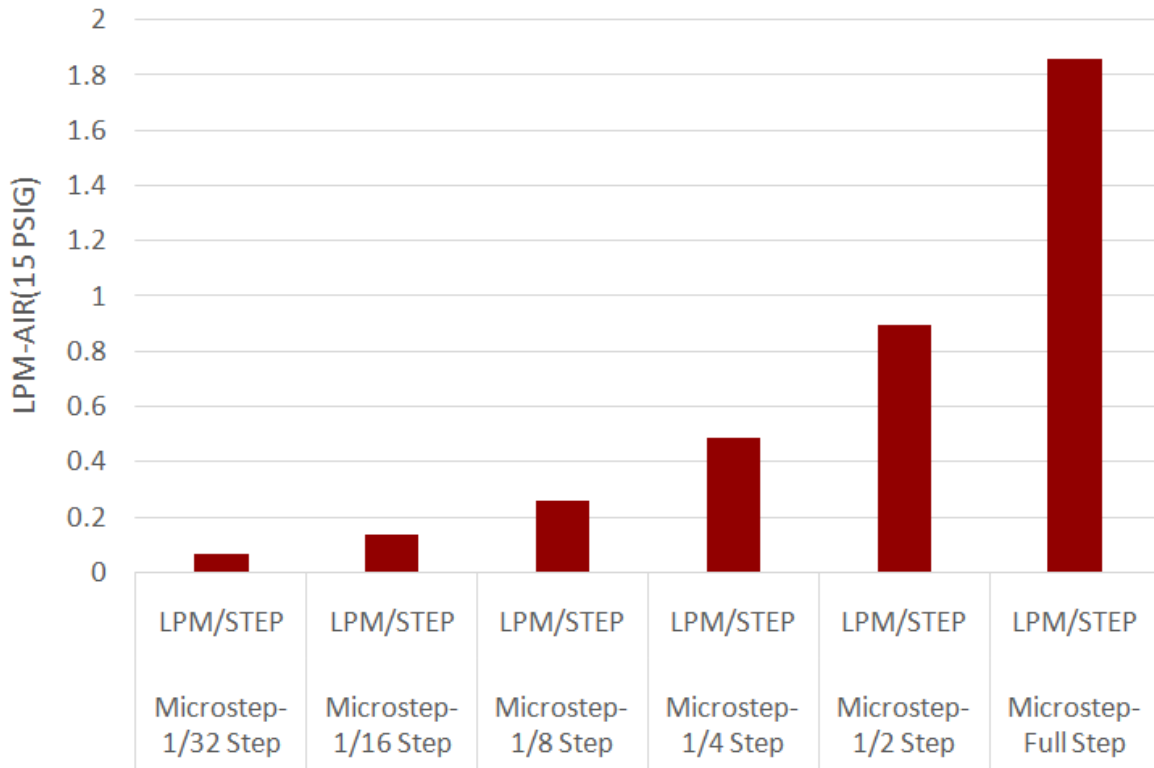

# THRUST vs SPEED PERFORMANCE CURVE

## Thrust vs Speed Curve

Bi-Polar Chopper Drive 100% Duty Cycle (.00048" Curve-J)

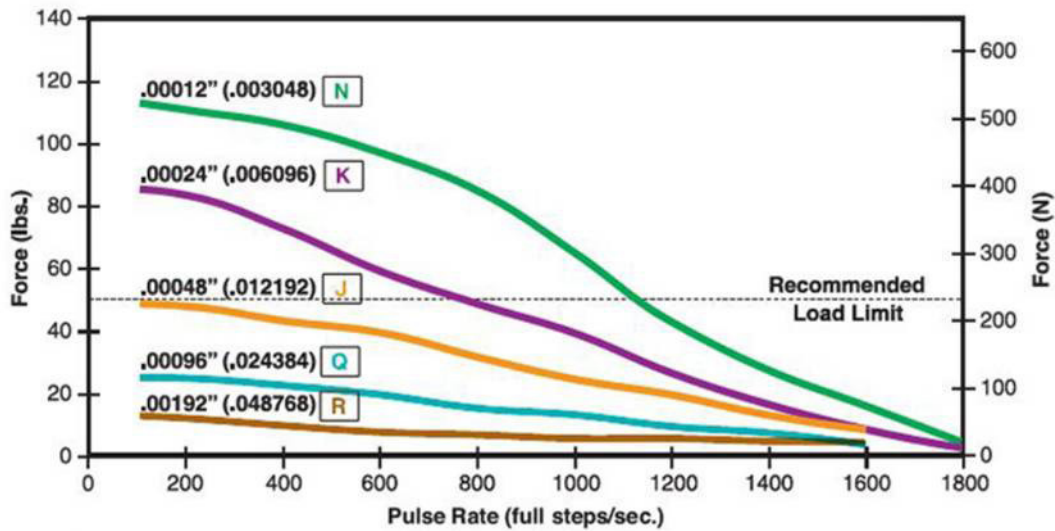

Note: All curves were generated with a 5 VDC motor and a 40 VDC power supply

## Typical Flow Curve

The flow curve below was generated using our MPPV-4 valve with Air at 15 PSIG in a 0.125" I.D. hose (0.250" O.D.). Note the linearity from full closed to step 150.

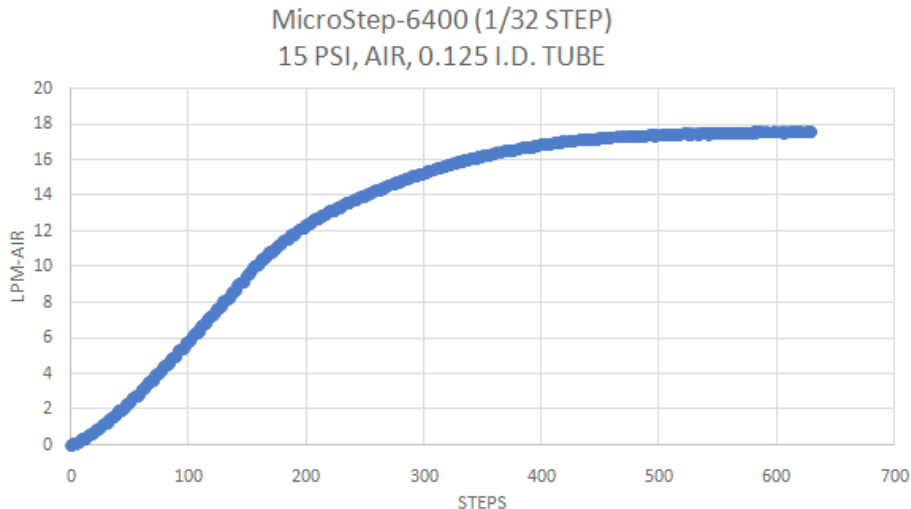

# CE CERTIFICATION & RoHS CERTIFICATION

**Resolution Air**  
A CONTROL VALVE REVOLUTION

## CE Declaration of Conformity

This declaration of conformity is issued under the sole responsibility of the manufacturer

Declarer's Name: Resolution Air, Ltd.  
Declarer's Address: 1776 Mentor Avenue  
Cincinnati, OH 45212

Type of Equipment: Control Valves  
Product Description: Pinch Valves  
Model No: MPPV, MPPV-HR, & HPPV Series

The object of the declaration described above is in conformity with the Directive 2001/65/EU of the European Parliament and of the Council of 8 June 2011 on the restriction of the use of certain hazardous substances in electrical and electronic equipment.

Directive: RoHS II Directive 2011/65/EU  
Article 4

We the undersigned, hereby declare that this equipment conforms with Annex IV of the Directive as verified by compliance with Article 4.

	January 30, 2017
_____ (signature)	_____ (Date)
Brad Thompson	Owner
_____ (printed name)	_____ (Title)

# RECOMMENDED TUBE TYPE

---

In addition to certification, system pressure and chemical compatibility must be considered in the tube selection process. A resilient tube, such as platinum cured silicone, serves as a good launching point for many applications, with a range of 50-65 Durometer, Shore A. A knowledgeable and experienced tubing supplier can offer users guidance in selecting the appropriate tubing for an application.



## Recommended Tubing Suppliers:



[Visit AdvantaSil Website](#)

## *Dow Corning*<sup>®</sup> Pharma Tubing

[Visit Dow Corning Website](#)



[Visit Watson Marlow Website](#)



[Visit Saint-Gobain Website](#)

# WIRING DIAGRAM with STEPPING SEQUENCE

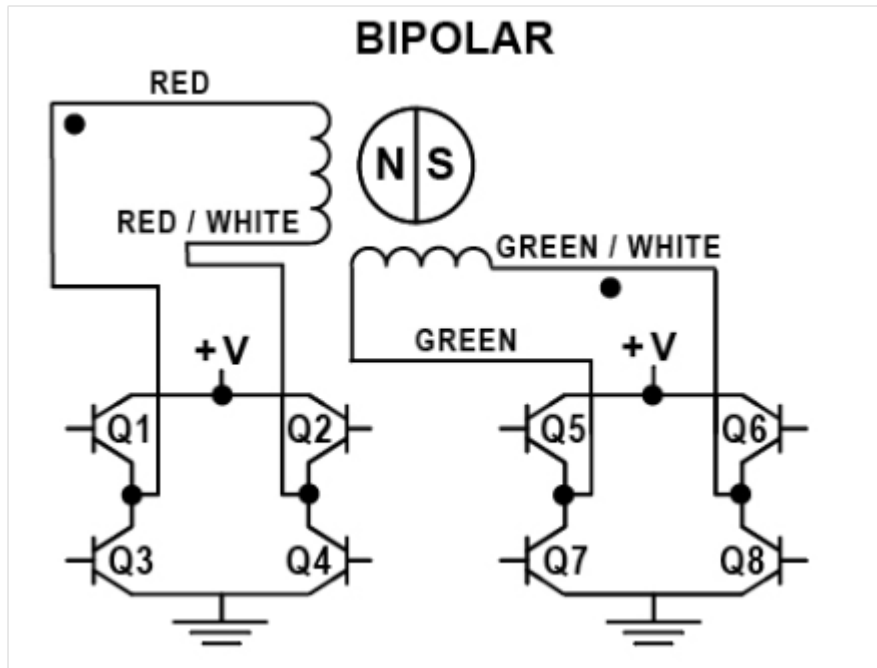

Stepping Sequence- Hybrid Linear Actuator

Extend CW ↓	Bipolar	Q2-Q3	Q1-Q4	Q6-Q7	Q5-Q8	Retract CCW ↑
	Unipolar	Q1	Q2	Q3	Q4	
	Step					
1	ON	OFF	ON	OFF		
2	OFF	ON	ON	OFF		
3	OFF	ON	OFF	ON		
4	ON	OFF	OFF	ON		
1	ON	OFF	ON	OFF		

# VALVE OPERATION

---

## Tube and Piston Clearance

When the piston is fully retracted, there is a nominal clearance of .031" between the top of the tube and the top of piston.

## Minimizing Cycle Times

Lowest cycle times are achieved by minimizing tube durometer and fluid pressure. In addition, fluid metering does not occur until the tube is partially pinched. Initially the shape of the tube is being changed prior to a reduction in tube cross sectional area. See flow curve. Therefore, extremely low cycle times can be generated by beginning a cycle with the tube partially pinched. This reduces the distance the piston will need to travel to be fully pinched. In addition, in order to achieve both high pinch force and low cycle time, valve speed can be changed throughout its travel. For example, the valve speed can be high initially but then as the tube approached the fully pinch state, speed can be reduced.

## Methods for Fully Pinching the Tube

The valve can be closed until the stepper motor stalls under full load. This method exceeds the recommended load limit and will reduce life of actuator.

The preferred method to completely pinch the tube is to close the valve until the tube is bubble tight and then continue an additional few steps. This maintains an accurate step count and also maximizes the life of the leadscrew nut and therefore the valve itself.  
Recommended Maximum Pinch Force - (50 lbs.)

Resolution Air, Ltd. recommends the recommended load limit is not exceeded in order to optimize valve performance and life. The curve below shows how the force is a function of motor speed. As the speed decreases the force available increases. In addition, the ramping of the speed can used to optimize valve performance.

**Contact us for questions and assistance (513) 318-4600**  
**[Sales@resolutionair.com](mailto:Sales@resolutionair.com)**

**Resolution Air**   
A CONTROL VALVE REVOLUTION